

**nora nTx**  
Saves time and money

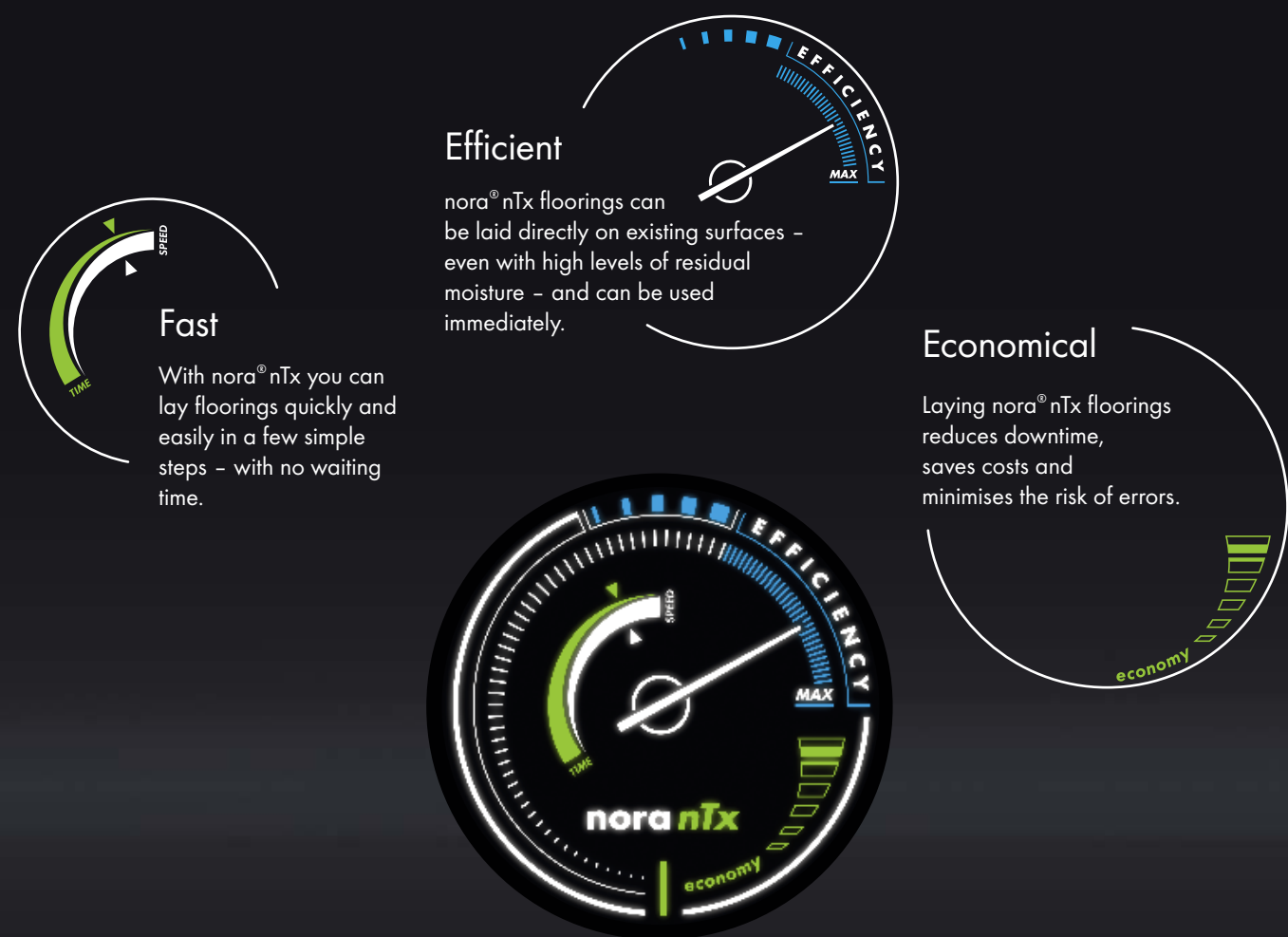

... when time is a decisive factor

In some situations, renovations and the downtime they cause can result in very high costs. In hospitals, for example, it's simply not possible to interrupt work or close wards.

Kindergartens, schools and universities all have very restricted time windows for renovations. In production facilities or office buildings too, even temporary closures are often impossible.

When time is a decisive factor, nora® nTx is the perfect solution. Whether new builds or renovations, choosing

nora® nTx saves you time and money. And you also get to benefit from the high quality and reliability of nora® rubber flooring systems.

nora® nTx combines the proven properties of nora® products – elasticity, durability and easy cleaning – with innovative installation technology. This self-adhesive flooring can be used immediately after laying and offers professionell installers new application areas.

Visit [www.ntx.nora.com](http://www.ntx.nora.com) and decide for yourself!

**nora nTx**  
It's a question of time



**nora systems Shanghai Co. Ltd.**

10 A/B, Long Life Building | 1566 Yan'an Road West | 200052 Shanghai, PR China  
Tel.: +86 21 - 3226 0077 | Fax: +86 21 - 5258 1958  
[www.nora.com/cn](http://www.nora.com/cn)

**nora systems GmbH (DMCC Branch)**

2008 HDS Business Centre | Jumeirah Lakes Towers | PO Box 478392 | Dubai, UAE  
Tel.: +971 (4) 450 8175 | Fax: +971 (4) 450 8374  
E-Mail: [info@nora.com](mailto:info@nora.com)  
[www.nora.com/corp](http://www.nora.com/corp)

**nora flooring systems UK Ltd.**

4-5 Allerton Road | Rugby CV23 0PA, Great Britain  
Direct Dial Numbers: (01788) 513 160 – 513 169  
Fax: (01788) 55 28 12  
E-Mail: [info-uk@nora.com](mailto:info-uk@nora.com)  
[www.nora.com/uk](http://www.nora.com/uk)

**nora systems GmbH**

Hoehnerweg 2-4 | 69469 Weinheim, Germany  
Tel.: +49 (0) 6201 - 80 66 33  
E-Mail: [info@nora.com](mailto:info@nora.com)  
[www.nora.com](http://www.nora.com)

117114.05/2015 N.

# nTx



A complete flooring system for all areas – easy to lay with instant bonding. Simple, effective and super fast.

Hospitals cannot afford downtime during renovations. Time is the key to success. Time that can be used to concentrate fully on patient recovery.

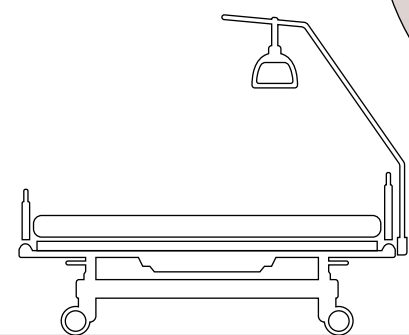

Whether in universities, schools or other educational institutions – the flooring can be laid so quickly that you will be ready to teach again before anyone notices the new floor covering.

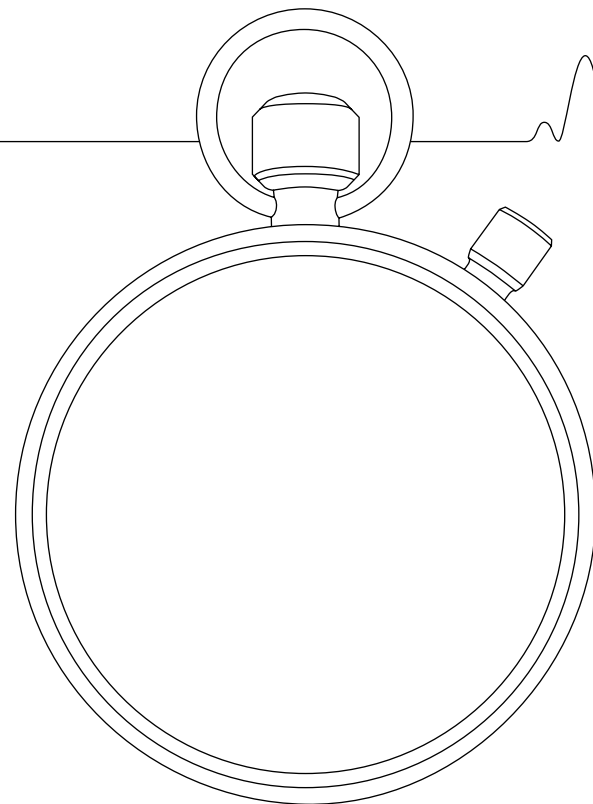

nora® nTx is suitable for all application areas, including new builds. Residual moisture in substrates is no problem. nora® nTx can be successfully laid even where there are high moisture levels. Saves time and money. No drying time and no waiting.



Experience the advantages of nora® nTx for yourself.

nora® nTx  
Lay it. Stick it. Use it.

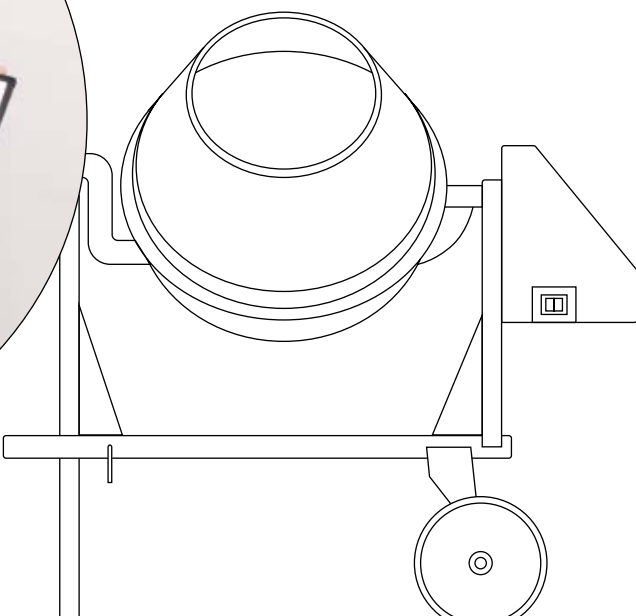

## nora nTx The new generation flooring system

nora® nTx is a new and unique technology for professional installers to lay nora® rubber flooring systems.

Because the powerful adhesive is factory-fitted, nora® nTx is as simple as it is ingenious. In a few simple steps, the flooring can be cleanly and safely installed and used immediately. It can be laid on all common concrete or cement screed surfaces, as well as directly on top of existing floorings. Even high levels of residual moisture in the screed are no problem for nora® nTx.

The challenges of conventional laying processes – such as applying the correct amount of adhesive or ensuring sufficient wetting, drying and waiting time before and after laying – are all a thing of the past. And the result is just as durable, sturdy and safe as you would expect from nora® floor coverings. No other rubber floorings offer so many time and cost savings for contractor and building users alike. All from a single supplier.

nora® nTx is available for noraplan® sentica, signa, unita, eco and stone. nora also offers a comprehensive range of installation materials and tools to ensure clean and safe substrate preparation.



You can find more information and details about the benefits of our nora® nTx flooring system at [www.ntx.nora.com](http://www.ntx.nora.com)

## nora nTx Features and benefits at a glance

- Fast and simple laying in just a few steps
- Even works perfectly with high residual moisture levels
- Can be directly laid on existing floor coverings
- No need to interrupt your daily work
- No drying or waiting time
- Can be used immediately after laying
- Complete system from a single supplier
- Minimised downtime – economical for operators of buildings with shared-use areas

For perfect substrate preparation, we offer a variety of nora® nTx installation materials. These have been developed specifically for the installation of nora® nTx floorings.

The perfect match between installation materials and flooring ensures functional safety and guarantees the highest standard of quality. In addition, all nora® nTx installation materials can also be used at higher residual moisture levels in the substrate.

- nora® nTx 010: Stable filler
- nora® nTx 015: Filler
- nora® nTx 020: 1-C primer



**noraplan® sentica nTx**  
Art. 1633 / 2.0 mm  
● 38\*  
~ 1.22 m x 14.8 m  
Art. 155A / 3.0 mm  
● 12\*  
~ 1.22 m x 11.8 m

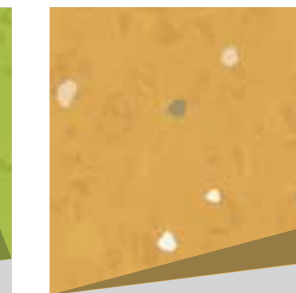

**noraplan® signa nTx**  
Art. 156A / 2.0 mm  
● 48\*  
~ 1.22 m x 14.8 m  
Art. 157A / 3.0 mm  
● 17\*  
~ 1.22 m x 11.8 m

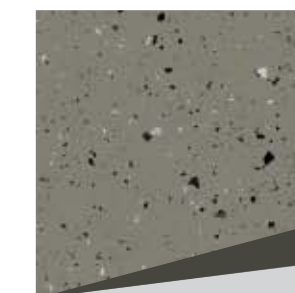

**noraplan® unita nTx**  
Art. 1698 / 2.0 mm  
With discretely dispersed granite chips  
● 12\*  
Art. 1699 / 2.0 mm  
With glimmering dispersed granite  
● 4\*  
~ 1.22 m x 14.8 m

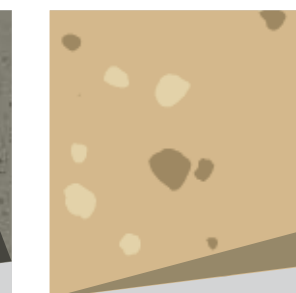

**noraplan® eco nTx**  
Art. 158A / 2.0 mm  
● 16\*  
~ 1.22 m x 14.8 m

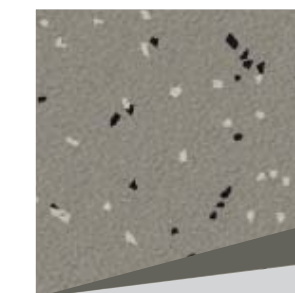

**noraplan® stone nTx**  
Art. 145A / 2.0 mm  
Reflection-breaking surface  
● 20\*  
Art. 147A / 2.0 mm  
Smooth surface  
● 8\*  
~ 1.22 m x 14.8 m

\* You can view our complete colour palette at [www.nora.com](http://www.nora.com)